



INSTALLATION MANUAL

LAWN SPRINKLER PUMPS

CONSUMER HOT-LINE: 1-800-942-3343 • MONDAY - FRIDAY • 7 AM to 5 PM

EASTERN
STANDARD
TIME

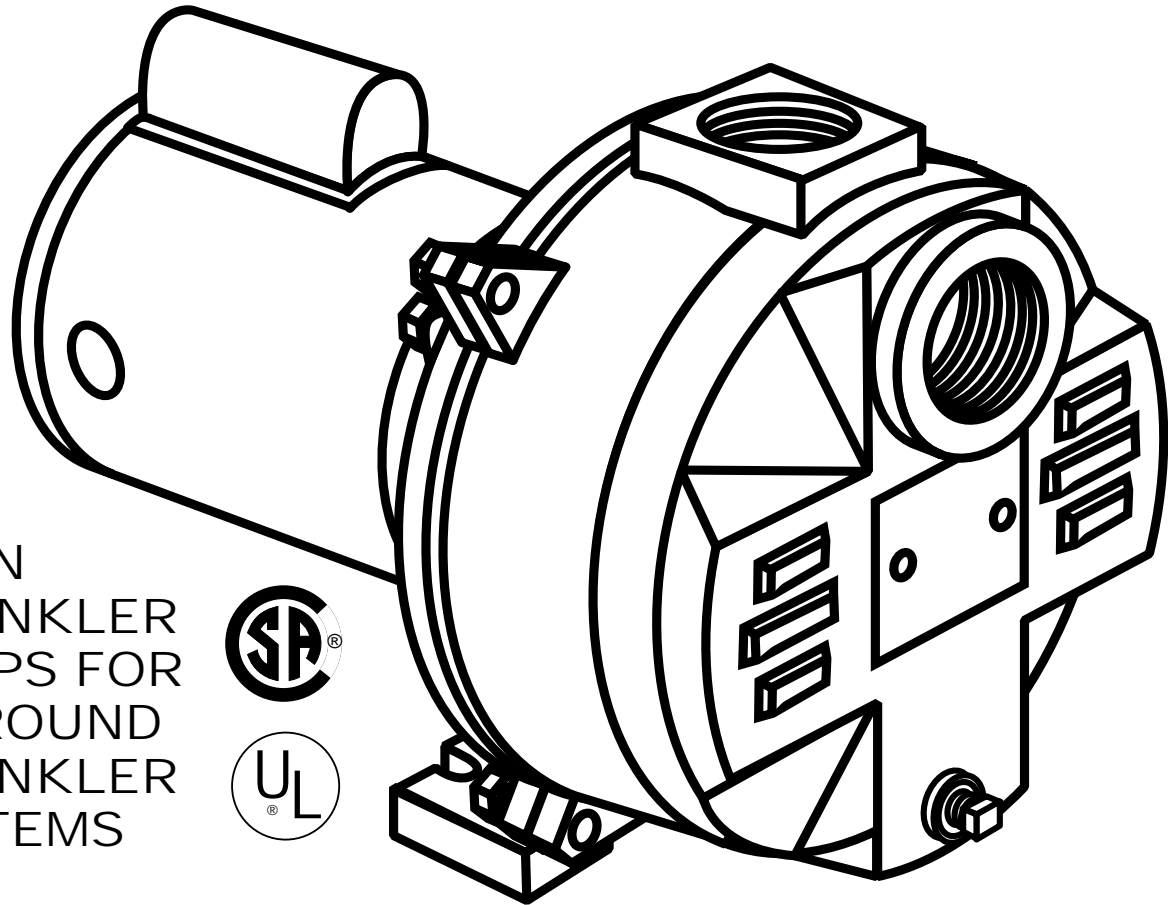

LAWN
SPRINKLER
PUMPS FOR
INGROUND
SPRINKLER
SYSTEMS

MODEL R7L
3/4 HP

MODEL R10L
1 HP

MODEL R15L
1 1/2 HP

MODEL R20L
2 HP

MODEL R25L
2 1/2 HP

WARRANTY: PRODUCT DEFECTS COVERED 12 MONTHS FROM DATE OF PURCHASE OR 18 MONTHS FROM DATE OF MANUFACTURE. RECEIPT AND PRODUCT DATE CODE REQUIRED FOR WARRANTY CLAIM.

WATER ACE PUMP COMPANY • ASHLAND, OHIO 44805-1969

IMPORTANT INSTRUCTIONS BEFORE INSTALLATION

Failure to follow these instructions may cause serious bodily injury and/or property damage.



Warning void if product modified, drilled, painted, or altered in any way; if used to pump hot water, or to pump liquids other than water (such as but not limited to chemicals, fertilizers, flammable liquids, herbicides, mud, tar, cement, wood chips); or otherwise abused.

1. Before installing or servicing your pump, BE CERTAIN pump power source is disconnected.
2. All installation and electrical wiring must adhere to state and local codes and must be complete before priming the pump. Check with appropriate community agencies, or contact your local electrical and pump professionals.
3. Pump should be installed in a dry, convenient location close to the well, with ample space for installation and servicing the well. A dry basement, pit, or utility room is an excellent choice when allowed by law.
4. **CALL AN ELECTRICIAN WHEN IN DOUBT.** Pump motor should be connected to a separate electrical circuit directly from main switch. There must be a fuse box or circuit breaker installed in this line. Plugging into existing outlets may cause low voltage at motor, resulting in blown fuses, tripping of motor overload, or burned out motor. **Refer to electrical specifications on the following page for electrical connections.**
5. It is mandatory that a permanent ground connection be made from the pump motor to the grounding bar at the service panel. Do not connect pump motor to a power supply until permanently grounded. For maximum safety, ground the pump motor to a circuit equipped with a fault interrupter device.
6. **Motor Grounding Instructions: WARNING**
Reduced risk of electric shock during operation of this pump motor requires the provision of acceptable grounding. **Caution: Failure to ground this unit properly may result in severe electrical shock.** If the means of connection to the supply-connection box is other than grounded metal conduit, ground the pump motor back to the service by connecting a copper conductor, at least the size of the circuit conductors supplying the pump motor, to the grounding screw provided on rib underneath wiring compartment cover. (See wire diagram.)
NOTE: N.E.C. requires pump motor be grounded at installation.
7. Voltage of power supply must match the voltage of the pump motor. The R20L and R25L are factory preset to 230V and will not operate at any other voltage. However, the R7L, R10L and R15L are dual voltage motors. They are preset to 230 volts, but may be converted to 115 volts by following the instructions in the diagram to the right. If motor is converted to 115V, an electrician should insure electrical and power leads can handle the higher amps.
8. During installation, cover well to prevent foreign matter from contaminating the well or later damaging the pump during operation. Test well water for purity. Chlorination may be necessary. Check local Health Department for proper testing and recommendations.

9. Hand pump new wells until clear. **Pumping sand or other sediment will seriously damage the pump and void warranty.** Periodic flushing will remove internal pump sediment buildup. TO FLUSH:
 - Remove 1-1/2" plug from top of discharge tee, or remove piping if no discharge tee has been installed.
 - Remove 1/4" plug from the lower front of pump.
 - Pour water into top of pump until water flowing from lower front of pump is clear.
 - Scrape out any stubborn debris from the lower front opening with a wire or pipe cleaner.
 - Reinstall pipes and plugs and reprime before returning pump to service.
10. The following may cause severe damage to pump and/or piping and will void warranty:
 - Failure to protect pump and piping against below freezing temperatures.
 - Pumping chemicals or corrosive liquids.
 - Pumping gasoline or other flammable liquids.
 - Using extension cords.
 - Using this pump in or near a swimming pool.
 - Running the pump dry. Follow priming instructions on page 5 step 8.
 - Use of garden hose as discharge or suction line.
11. **CAUTION:** Running the pump without discharge water flow will cause serious damage inside the pump due to heat buildup.

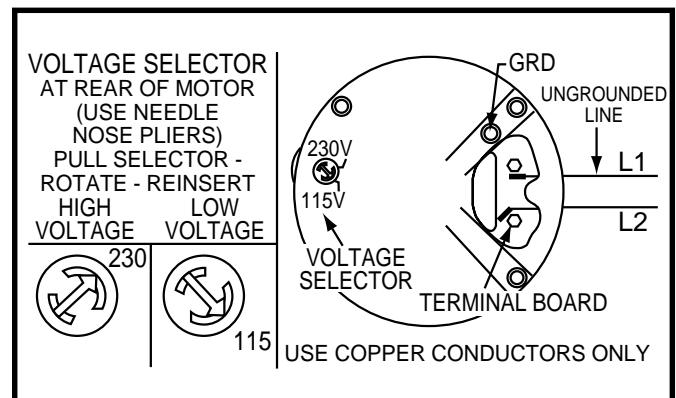

FINDING THE DEPTH OF YOUR WELL (For cased shallow wells only)

Tie a small but heavy weight to the end of a piece of string. Lower the weight into the well until it reaches the bottom. Take up the slack and mark the string at ground level. Pull the weight out of the well and measure from the bottom of the weight to the ground level mark. This is the depth of your well. Subtract five feet from the depth of your well. This number should not exceed 25 feet. If it does, it will greatly hinder or prevent the proper operation of a lawn sprinkler pump.

PIPING

Plastic PVC pipe is shown in the illustrations, but galvanized steel pipe may be used if desired. All piping must be clean and free of all foreign matter to prevent clogging. **ALL JOINTS AND CONNECTIONS IN THE**

WELL ASSEMBLY MUST BE AIRTIGHT. Even a pin-hole leak will prevent the proper operation of the pump (this is the most common problem). Use thread compound on all threaded joints unless specified otherwise.

SPECIFICATIONS

FUSE/BREAKER & WIRE SELECTION GUIDE

PUMP MODEL	HP	VOLTS*	NAME PLATE AMPS	LOCKED ROTOR AMPS	FAST ACTING FUSE	SLOW ACTING FUSE**	CIRCUIT BREAKER	MAX. WIRE LENGTH USING AWG SIZE			
								#14	#12	#10	#8
R7L	.75	115	12.2	64	20	15	20	90	145	230	370
		230	6.1	32	10	10	15	360	580	920	1480
R10L	1.0	115	13.6	64	25	20	25	80	130	205	330
		230	6.8	32	10	10	15	320	520	820	1320
R15L	1.5	115	17.0	78	30	25	30	65	105	165	260
		230	8.5	39	15	15	15	260	400	660	1040
R20L	2.0	230	11.0	47	20	15	20	200	320	500	800
R25L	2.5	230	13.5	58	20	20	25	160	260	420	660

* Motors are pre-set for 230 volts; R7L, R10L and R15L may be converted to 115 volts per instructions printed on motor.

** FUSETRON – Cartridge Type or FUSTAT – Plug Type.

NOTE: Consult with a licensed electrician or refer to the National Electric Code for definitive guide to wire size and circuit protection devices.

PUMP CAPACITIES

PUMP MODEL	HP	DISCHARGE PRESSURE PSI	CAPACITY IN G.P.M. FOR DISCHARGE PRESSURE & TOTAL SUCTION LIFT INDICATED				MAXIMUM TOTAL SHUT OFF HD.		APPROX. WT. LBS.
			10 FT.	15 FT.	20 FT.	25 FT.	FEET	PSI	
R7L	.75	15	42	38	36	26	103	45	49
		20	37	34	32	25			
		25	32	29	27	24			
		30	27	23	20	12			
		35	18	10	—	—			
R10L	1.0	15	48	45	37	27	106	46	49
		20	45	42	36	26			
		25	40	37	34	25			
		30	33	30	26	20			
		35	25	20	—	—			
R15L	1.5	15	51	48	41	29	106	46	52
		20	48	45	40	28			
		25	43	42	37	27			
		30	37	35	31	26			
		35	26	22	—	—			
R20L	2.0	15	62	53	44	33	107	46	63
		20	61	52	43	32			
		25	60	51	41	31			
		30	52	48	39	30			
		35	43	36	27	—			
R25L	2.5	15	66	57	47	35	110	48	67
		20	65	56	46	34			
		25	64	55	45	33			
		30	60	54	44	32			
		35	50	43	36	25			

NOTE: Performance will be reduced slightly by the foot valve; but the use of a foot valve is recommended.

INGROUND LAWN SPRINKLER PUMP INSTALLATION

The R7L, R10L, R15L, R20L, and R25L pumps are all recommended for inground lawn sprinkler applications. The pumps with higher horsepower provide greater pumping capacity. Materials with part numbers are quality Water Ace parts.

General Materials

- One can PVC cement (read instructions carefully)
- One can thread compound (read instructions carefully)
- One 1-1/2" Foot Valve #RFV-15
- Three male 1-1/2" PVC Adapters
- Enough rigid 1-1/2" PVC pipe and couplings to reach from bottom of well to pump.
- One 1-1/2" well seal
- One 1-1/2" PVC Elbow
- One 1-1/2" Discharge Tee #RDT-15
- One 1-1/2" Pipe Plug
- Enough rigid 1-1/2" PVC pipe to reach from pump to service line.

In addition to General Materials, for Well Points only

- Enough galvanized 1-1/2" pipe and couplings to reach from bottom of well to one foot above ground level
- One 1-1/2" galvanized Elbow
- One 1-1/2" galvanized Nipple
- One 1-1/2" Check Valve #RCV-15
- One 1-1/2" Male PVC Adapter

Tools Needed for all pump installations

Pipe wrench, pipe clamp, crescent wrench, slot screwdriver, 24-tooth hacksaw, knife or round file

REMINDER: ALL JOINTS AND CONNECTIONS MUST BE AIR-TIGHT. A SINGLE PIN-HOLE LEAK WILL PREVENT THE PROPER OPERATION OF THE PUMP. USE THREAD COMPOUND ON ALL THREADED CONNECTIONS UNLESS SPECIFIED OTHERWISE.

STEP 1 Thread 1-1/2" male PVC adapter into Foot Valve #RFV-15. Hand tighten, then tighten 1/4 turn with wrench.

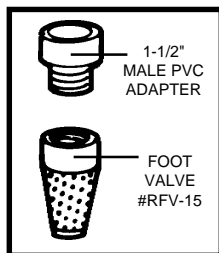

STEP 2 Subtract four feet from the depth of your well (See "Finding the Depth of Your Well" on page 2). This is the total length of rigid PVC pipe and couplings to cement onto the 1-1/2" male PVC adapter. Cement one section of rigid PVC pipe to the PVC adapter which is connected to the foot valve, then lower the whole

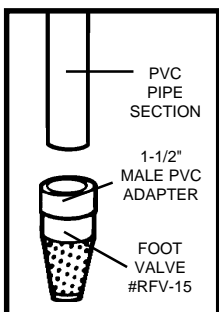

STEP 2 CONT'D assembly into the well, foot valve first. Firmly clamp the end of the rigid PVC pipe with a pipe clamp to prevent the assembly from sliding down into the well.

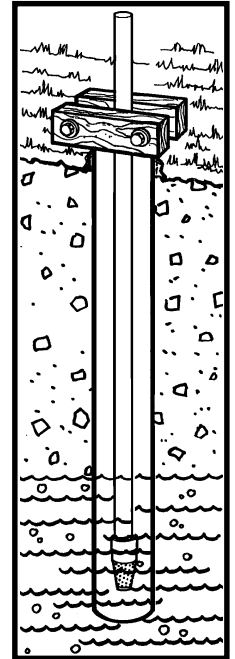

STEP 3 Cement as many couplings and sections of rigid PVC pipe as it takes to equal the depth of your well minus four feet, then firmly clamp the assembly with a pipe clamp to prevent the assembly from sliding down into the well.

STEP 4 Remove pipe clamp and slide the 1-1/2" well seal over rigid PVC pipe and onto well casing. Position assembly so that twelve inches of rigid PVC pipe protrude from well seal. Alternately turn bolts on well seal clockwise until rubber gaskets are tight against well casing and rigid PVC pipe.

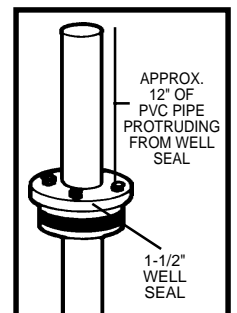

STEP 5 Cement 1-1/2" PVC elbow onto rigid PVC pipe protruding from well seal. If desired, some length may be cut off of rigid PVC pipe before cementing elbow. Smooth the inside of any rigid PVC pipe that has been cut with a round file or knife.

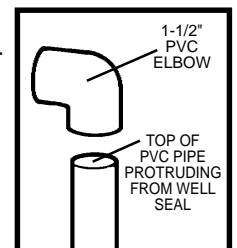

STEP 6 Thread a 1-1/2" male PVC adapter into front of pump. Hand tighten, then turn 1/4 turn with wrench.

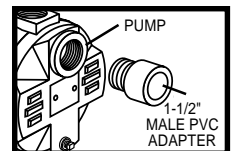

STEP 7

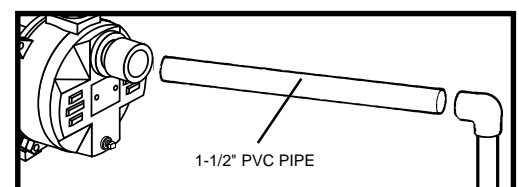

Cement as many sections and couplings of PVC pipe needed to connect the PVC elbow to the 1-1/2" male PVC adapter in the front of the pump.

STEP 8 Using pipe wrench, thread 1-1/2" Discharge Tee #RDT-15 into top of pump. Remove 1-1/2" plug from top of discharge tee. Put a garden hose into top of discharge tee. Fill pipes and pump until water overflows from top of discharge tee. This may take several minutes.

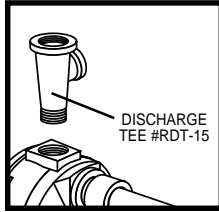

STEP 9 Thread the 1-1/2" pipe plug back into the top of Discharge Tee #RDT-15.

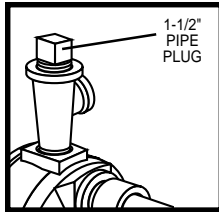

STEP 10 Complete all electrical connections as specified on pages 1 and 2 in the pre-installation instructions.

STEP 11 Place a large bucket beneath discharge tee outlet. Start motor. If pump is off-set from well 4 feet or more, it may take a few minutes for pump to prime. **Failure to prime in 5 minutes:** Stop motor, remove 1-1/2" plug from discharge tee, add more water, try again.

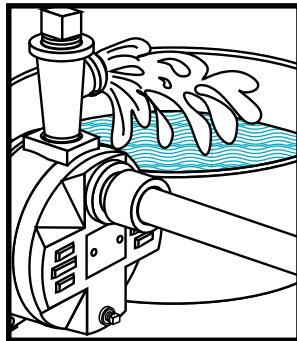

STEP 12 Allow pump to run long enough to clear well of sediment and to insure well will not run dry. Stop motor. Thread 1-1/2" male PVC adapter into discharge tee outlet.

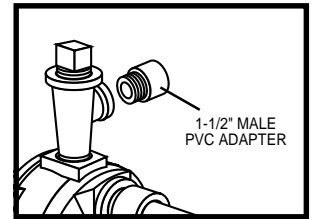

STEP 13 Cement as many PVC pipe sections and couplings as needed to connect the 1-1/2" male PVC adapter to inground sprinkler system. Complete installation should look like figure below.

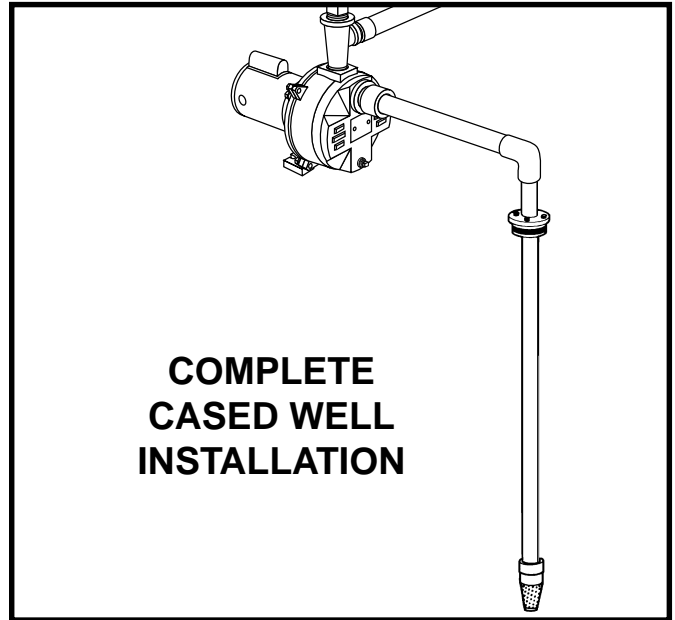

WELL POINT PUMP INSTALLATION

Materials needed in addition to Shallow Well General Materials, for Well Points only

- Enough galvanized 1-1/2" pipe and couplings to reach from bottom of well to one foot above ground level
- One 1-1/2" galvanized Elbow
- One 1-1/2" galvanized Nipple
- One 1-1/2" Check Valve #RCV-15
- One 1-1/2" Male PVC Adapter

STEP 1: Drive well point according to instructions included with well point. Use as much galvanized pipe and couplings as needed to both reach water and leave approximately one foot of pipe protruding from ground.

STEP 2: Thread 1-1/2" galvanized elbow onto pipe protruding from ground.

STEP 3: Thread 1-1/2" galvanized nipple into the 1-1/2" galvanized elbow.

STEP 4: Thread 1-1/2" Check Valve #RCV-15 onto 1-1/2" galvanized nipple.

STEP 5: Thread 1-1/2" Male PVC Adapter into 1-1/2" Check Valve #RCV-15.

STEP 6: Follow steps 6-13 in cased well instructions. Total installation should look like the drawing to the right.

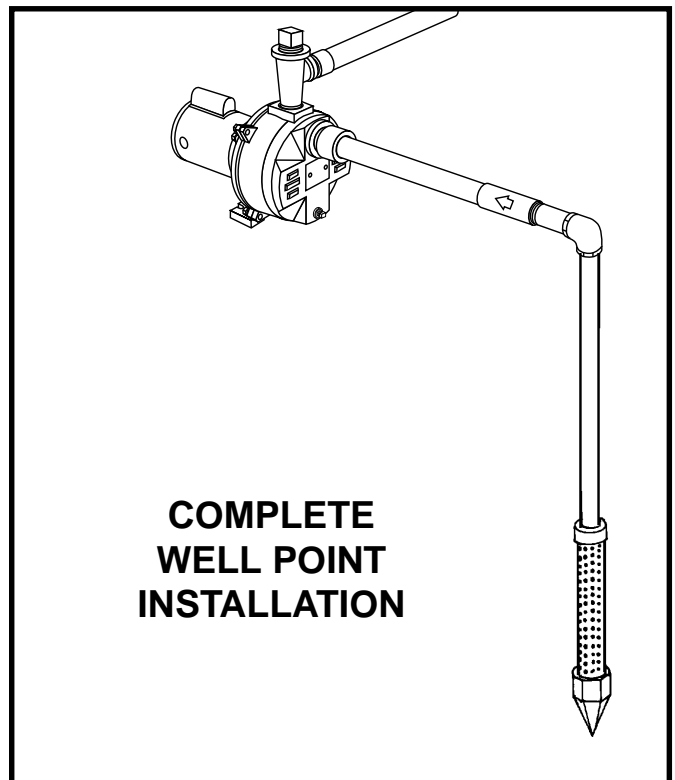

MULTIPLE WELL POINTS

In a well point application, it is very common to combine the suction of several well points in order to match the higher flow capability of the pump. When using an inground lawn sprinkler pump with multiple well points, maintain as equal a distance between well points as possible. Refer to the illustration to the right. Consult with your pump professional for appropriate materials and installation instructions.

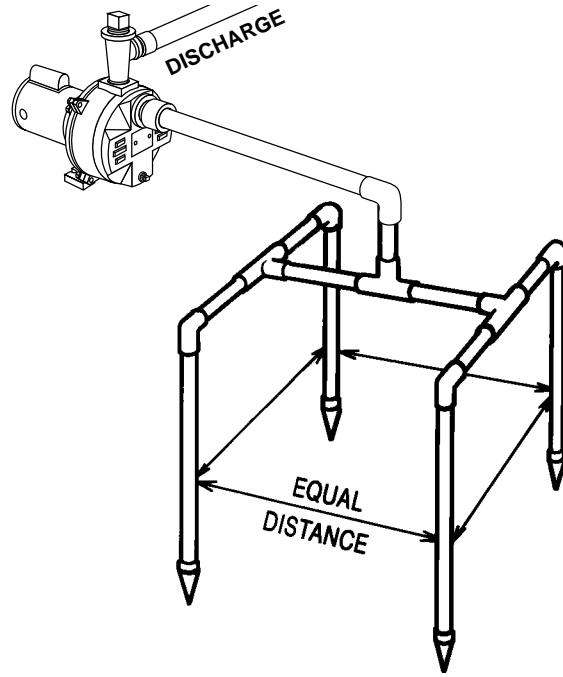

DRAINING FOR SERVICING OR FOR WINTER

The pump should be drained before it is disconnected for servicing, or if it is inoperative for an extended period of time, or if it is in danger of freezing. To drain:

- Remove 1-1/2" pipe plug from discharge tee.
- Remove the 1/4" plug from the lower front of pump.
- Drain all piping to a point 3 feet below ground level.

TROUBLESHOOTING CHECKLIST (CAUTION: SHUT OFF POWER TO PUMP)

PROBLEM	POSSIBLE CAUSES
Pump will not prime	<ul style="list-style-type: none"> • Not enough water. Stop motor, remove 1-1/2" pipe plug, and fill case with water. • Pump wired incorrectly. Voltage of pump should match voltage of power supply. • Plugged impeller, check valve, suction piping, foot valve, or well point. • Foot valve is sitting in sand or mud, or is stuck shut, or leaks. • Well depth exceeds pump capability. • Leaks. Check all connections for airtightness. • Leaky shaft seal.
Pump does not deliver rated capacity	<ul style="list-style-type: none"> • Insufficient submergence of suction pipe; should be at least 3 feet below water level. • Pump wired incorrectly. Voltage of pump should match voltage of power supply. • Plugged impeller, check valve, suction piping, foot valve, or well point. • Discharge system head is too great. • Well depth exceeds pump capability. • Pump flow is greater than well flow capability. • Leaks. Check all connections for airtightness. • Suction pipe is too small. Should be 1-1/2" pipe.
Pump loses prime after starting	<ul style="list-style-type: none"> • Insufficient submergence of suction pipe; should be at least 3 feet below water level. • Well depth exceeds pump capability. • Pump flow is greater than well flow capability. • Leaks. Check all connections for airtightness.
Pump vibrates or is noisy	<ul style="list-style-type: none"> • Insufficient pump foundation. • Well depth exceeds pump capability. • Bent shaft, worn motor bearing, or clogged impeller.
Motor overheats and shuts off (overload)	<ul style="list-style-type: none"> • Motor voltage does not match power supply voltage. • Improper wire size. See Wire Size Guide on page 3. • Impeller is rubbing against pump case.
Motor fails or does not operate properly	<ul style="list-style-type: none"> • If within Warranty, return pump/motor unit to place of purchase (with proof of purchase) for exchange.

PUMP DISASSEMBLY

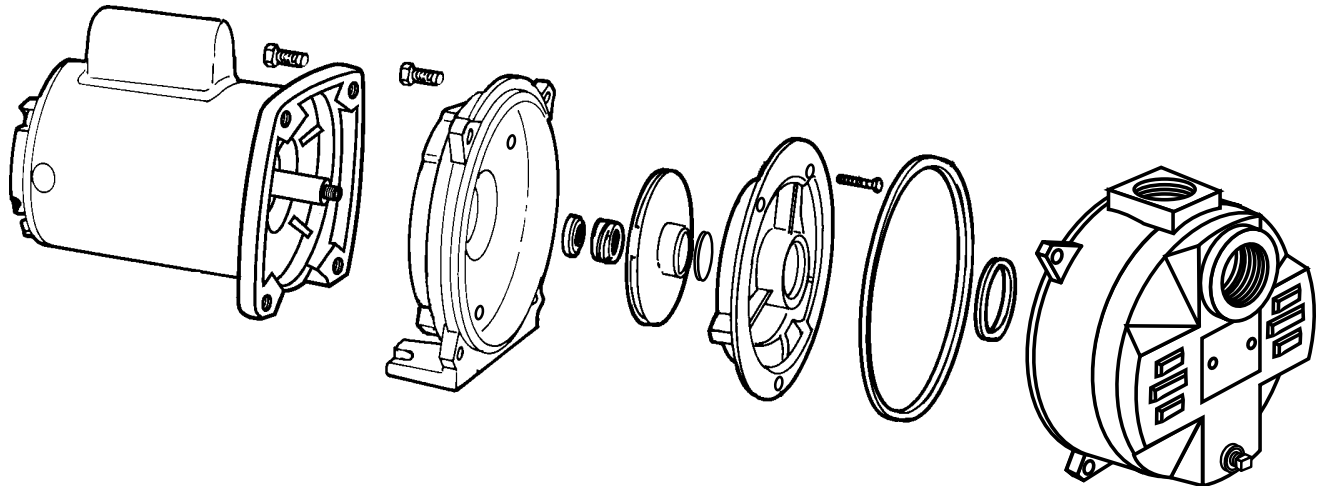

REPAIR KITS

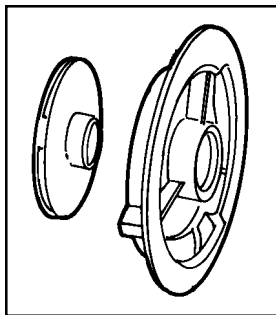

DIFFUSER & IMPELLER

Kit RPK-7LS for the R7L
Kit RPK-10LS for the R10L
Kit RPK-15LS for the R15L
Kit RPK-20LS for the R20L
Kit RPK-25LS for the R25L

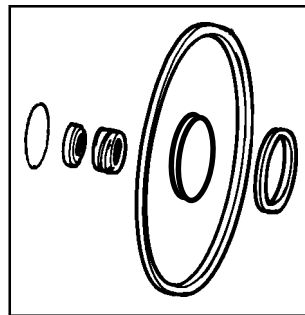

KIT RPK-LSS

Includes shaft seal,
impeller seal, slinger,
gasket 8-3/4od, gasket
2-1/8od which fit all 5
lawn sprinkler pumps

LIMITED WARRANTY

WATER ACE PUMP CO. will repair or replace for the original user any portion of a new WATER ACE product which proves defective due to materials or workmanship of WATER ACE PUMP CO. Contact the nearest authorized WATER ACE PUMP dealer for warranty service. WATER ACE PUMP CO. shall possess the sole right to determine whether to repair or replace defective equipment, parts or components. THIS WARRANTY DOES NOT COVER DAMAGE DUE TO LIGHTNING OR OTHER CONDITIONS BEYOND THE CONTROL OF WATER ACE PUMP CO.

PUMPS: Warranted 12 months from date of purchase or 18 months from date of manufacture. Receipt and product date code required for warranty claim.

LABOR & COSTS: WATER ACE PUMP CO. shall IN NO EVENT be liable for the cost of field labor or other charges incurred by any customer in removing and/or reaffixing any WATER ACE PUMP product, part or component.

THIS WARRANTY WILL NOT APPLY: (a) to defects or malfunctions resulting from failure to properly install, operate, or maintain the unit in accordance with printed instructions provided; (b) to failures resulting from abuse, accident, or negligence; (c) to normal maintenance services and the parts used in connection with such service; (d) to units which are not installed in accordance with applicable local codes, ordinances, and good trade practices; (e) if the unit is moved from its original installation location; (f) if unit is used for purposes other than for what it was designed and manufactured.

PRODUCT IMPROVEMENTS: WATER ACE PUMP CO. reserves the right to change or improve its products or any component without obligation to provide such a change or improvement for units previously sold and/or shipped.

WARRANTY EXCLUSIONS: WATER ACE PUMP CO. SPECIFICALLY DISCLAIMS THE IMPLIED WARRANTIES OF MERCHANTABILITY AND FITNESS FOR A PARTICULAR PURPOSE AFTER THE TERMINATION OF THE WARRANTY PERIOD SET FORTH HEREIN.

Some states do not permit some or all of the above warranty limitations and, therefore, such limitations may not apply to you. No warranties or representations at any time made by any representatives of WATER ACE PUMP CO. shall vary or expand the provision hereof.

LIABILITY LIMITATION: IN NO EVENT SHALL WATER ACE PUMP CO. BE LIABLE OR RESPONSIBLE FOR CONSEQUENTIAL, INCIDENTAL OR SPECIAL DAMAGES RESULTING FROM OR RELATED IN ANY MANNER TO ANY WATER ACE PUMP PRODUCT OR PARTS THEREOF. PERSONAL INJURY AND/OR PROPERTY DAMAGE MAY RESULT FROM IMPROPER INSTALLATION. WATER ACE PUMP CO. DISCLAIMS ALL LIABILITY, INCLUDING LIABILITY UNDER THIS WARRANTY, FOR IMPROPER INSTALLATION – WATER ACE PUMP CO. RECOMMENDS FOLLOWING THE INSTRUCTIONS IN THE INSTALLATION MANUAL. WHEN IN DOUBT, CONSULT A PROFESSIONAL.

Some states do not allow the exclusion or limitation of incidental or consequential damages, so the above limitation or exclusion may not apply to you.

This warranty gives you specific legal rights and you may also have other rights which vary from state to state.

In the absence of suitable proof of this purchase date, the effective date of this warranty will be based upon the date of manufacture.

Direct all Notices, etc. to: Product Warranty and Return Dept., Water Ace Pump Co., 1101 Myers Parkway, Ashland, OH 44805-1969.

Water Ace Pump Co. • 1101 Myers Parkway • Ashland, Ohio 44805-1969

1-800-942-3343 (U.S.A. only)